

## CABLING

Cables are to be selected in accordance with the requirements of the current issue of BS5839. Two pairs of connection terminals (L+ and L-) are provided on the terminal block. These terminals are used for connecting the module on to the addressable circuit. A maximum of one 1.5mm<sup>2</sup> or one 2.5mm<sup>2</sup> cable may be connected at any one terminal.

## ADDRESS PROGRAMMING

The EV-Mini IP must be set to the loop address of the device using EV-AD2 address programming tool. The EV-Mini IP is programmed with the address using the programming port, as above.

**Note:** Once the address has been programmed, take note of the device location and address number to include on site drawings.

## ORDERING INFORMATION

EV-Mini IP Input Module: F16N82025

Fig. 4 EV-Mini IP Wiring Diagram - Non-Interrupt Mode

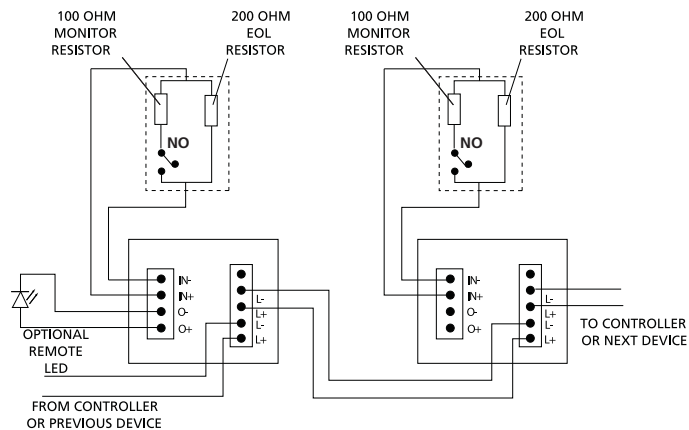

STYLE 'C' NORMALLY OPEN - FAULT ON SHORT CIRCUIT

## TECHNICAL SPECIFICATION

|                                |  |
|--------------------------------|--|
| Type Identification Value:     | 51   |
| System Compatibility:          | Use only with Evolution Fire Alarm Panels (CIE) which support this unit  |
| Environment:                   | Indoor Application only  |
| Operating Temperature:         | -25°C to +70°C   |
| Storage Temperature:           | -40°C to +80°C   |
| Operating Humidity:            | Up to 95% non-condensing   |
| Dimensions (HWD):              | 57 x 48 x 13mm   |
| Mounting Requirements:         | Any suitable electrical enclosure  |
| Wire Size:                     | Min 1.5mm <sup>2</sup><br>Max 2.5mm <sup>2</sup>   |
| Battery Requirements:          |  |
| Standby Alarm:                 | 0.46mA   |
| (without remote LED):          | 0.46mA   |
| Alarm                          |  |
| (with remote LED):             | 4.5mA  |
| Maximum Wiring Resistance:     |  |
| Monitored Circuit:             | 10Ω  |
| Addressable Device Conditions: |  |
|                                | <ul style="list-style-type: none"> <li>• Normal</li> <li>• Active</li> <li>• Short Circuit wiring fault</li> <li>• Open Circuit wiring fault</li> <li>• Device Type invalid</li> <li>• Device No Response</li> </ul> |



Fig. 1 EV-Mini IP Mini-Input Module

## ELECTROMAGNETIC COMPATIBILITY

The EV-Mini IP complies with the following:

Product family standard EN 50130-4 in respect of Conducted Disturbances, Radiated Immunity, Electrostatic Discharge, Fast Transients and Slow High Energy.

EN 61000-6-3 for emissions.

## INTRODUCTION

The **EV-Mini IP** Mini Input module is designed to monitor fire contacts, such as extinguishing system control, ventilation control, fire door control etc. The module provides one identifiable detection spur which is capable of monitoring multiple normally open contacts.

The **EV-Mini IP** can be mounted in any electrical enclosure with sufficient depth to accommodate **EV-Mini IP** and the contacts monitored by the IN+ and IN- terminals, ie, no field wiring.

The remote LED (if required, not supplied) must be located within the same electrical enclosure.

## FEATURES

**EV-Mini IP** monitors the following types of contacts:

- Multiple normally open contacts

**EV-Mini IP** identifies and communicates the status of monitored contacts and wiring to the Evolution CIE.

**EV-Mini IP** contains an output for an external LED (not supplied). As a status indicator, the LED lights when the monitored contact (normally off) switches to an active state.

## WIRING NOTES

The following notes apply:

- 1) There are no user-required settings (switches, headers) on the **EV-Mini IP**.
- 2) All wiring must conform to the current IEE Wiring Regulations and BS5839 part 1. All conductors to be free of earths.
- 3) Mount the **EV-Mini IP** within a suitable electrical enclosure.
- 4) Verify the correct polarity of wiring before connecting the **EV-Mini IP** to the addressable loop circuit.
- 5) Configure the **EV-Mini IP** with its unique address, using the EV-AD2 Address Programming tool either before or after connecting **EV-Mini IP** to the Evolution addressable loop.
- 6) If connecting an external LED to the **EV-Mini IP**, the LED must be located within the same electrical enclosure as the **EV-Mini IP**. Use LED rated for 10mA.
- 7) Devices/contacts monitored by the **EV-Mini IP** must be located within the same electrical enclosure as the **EV-Mini IP**.

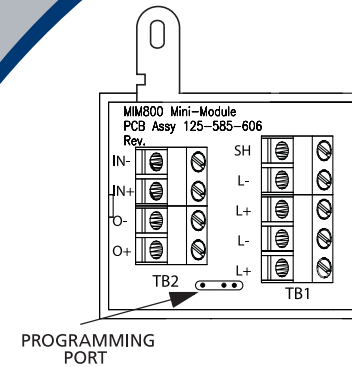

Fig. 2 EV-Mini IP PCB